

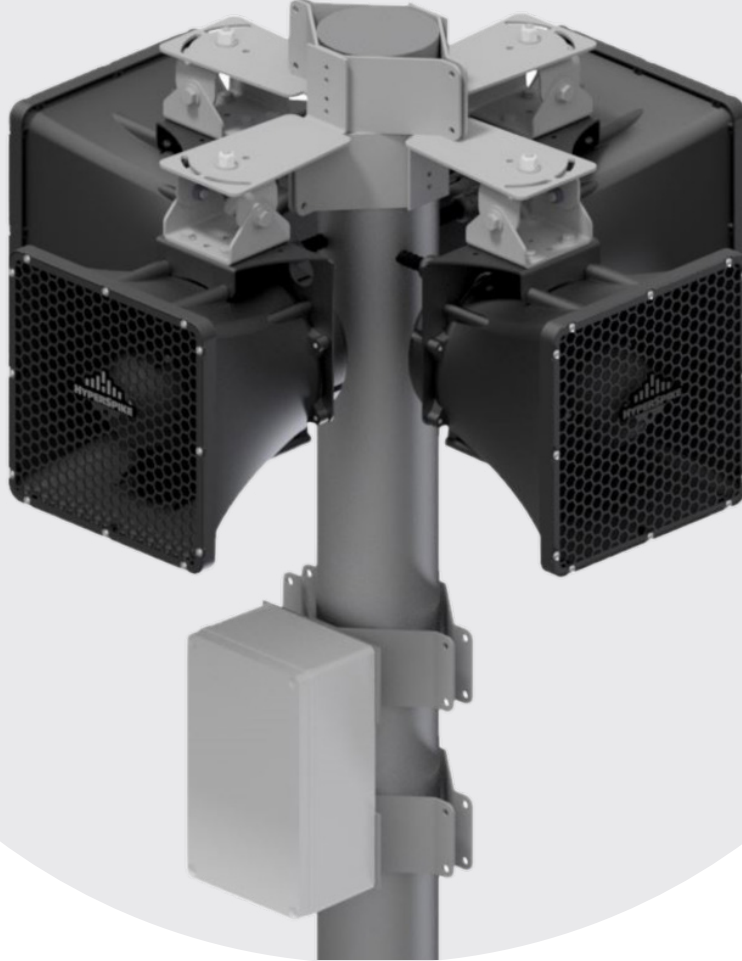

# TCPA-Q Array

Outdoor Wide Area Notification Solution



## Key features

- Cost Effective Outdoor Notification
- 135 dB Acoustic Output
- Lightweight and Small Footprint
- Excellent Voice Intelligibility Rating
- UL1480 Speaker System
- UL62368 Amplification System
- CID2 Listed Speaker System
- Multiple Input Options (Analog Audio / IP)
- Multiple Array Configurations

## Overview

The HyperSpike® TCPA-Q Array is a modular, omni-directional high power speaker system that broadcasts live and pre-recorded voice commands and tones over large outdoor spaces. Similar to its higher power counterparts (MA-1, MA-2), the TCPA-Q Array provides industry leading voice intelligibility, ensuring commands are clearly heard in large outdoor venues. Although not as powerful as HyperSpike's Outdoor MA-Series Speakers, the TCPA-Q Array provides a low-cost solution with various configuration options based on your needs. This provides flexibility and cost savings for applications that may not need the power of the MA-Series Speakers.

This new configuration of the highly efficient and proven TCPA-Q is designed to meet the growing needs of the outdoor notification market while continuing the HyperSpike® tradition of exceeding expectations and providing quality solutions that save lives.



## Technical Specifications

Array Specifications	4 Horn Array	8 Horn Array
dB SPL Max @ 1m*	135 dB	141 dB
Vertical Coverage -3dB (AVG 1kHz - 5kHz)	± 30°	
Frequency Response (±6dB)	375Hz-15kHz	
Nominal Speaker Impedance	Transformer Input - 70V	
Usable Range @ 80dB, A-weighted	600m (2000ft)	1200m (4000ft)
Acoustic Dispersion (AVG 1 kHz - 5kHz)	360° or Directional (see manual)	
Color (-XX)	Black -01, White -06, Red -05, Gray -04 (Silk Gray Mount)	
Speaker Material	Composite/Powder Coated Aluminum	
Voice Intelligibility Rating	Excellent (STI <sub>PA</sub> )	
Certification	UL1480 (Indoor/Outdoor), ULC, Class1Div2	
Production Dimensions (in)	24" Diameter x 13" H	24" Diameter x 26" H
Speaker Weight (lbs)	70 lbs (includes transformer)	140 lbs (includes transformers)

\* Based on Omni Directional Configuration

## Ordering Info

Array Part Numbers	Qty 1 - 90309A-801-XX	Qty 2 - 90309A-801-XX
Color (-XX)	Black -01, White -06, Red -05, Gray -04 (Silk Gray Mount)	
Included w/ Array	Qty 4 - TCPA-10s Qty 1 - 70V Transformer All Mounting Brackets and Hardware	Qty 8 - TCPA-10s Qty 2 - 70V Transformers All Mounting Brackets and Hardware
Electronic Cabinet (Analog)	Qty 1 - 90250A-801	Qty 1 - 90250A-802
Electronic Cabinet (Analog/Digital)	Qty 1 - 90272A-801	Qty 1 - 90272A-802
Output Power	300W	600W
Source Power	AC Primary / DC Backup	AC Primary / DC Backup

## Architect and Engineer Specifications

The TCPA-Q Array shall be a HyperSpike® model 90309A-801-XX providing alarm tone and pre-recorded or live voice announcements at \_\_\_ dB, measured at 1 meter from the source. The emitter shall be a combination of TCPAs weighing no more than \_\_ lbs. The emitter shall be able to transmit a 80 dB (LAeq) audible signal at \_\_\_\_\_ ft and operate at a power of \_\_\_W. The emitter shall be suitable for outdoor locations and shall include UL1480 listing along with Class 1 Division 2 Hazardous Location Certifications.

Note: Please see Models and Technical Specifications to fill in the blanks for specific speaker selection.



## One Product - Multiple Array Configurations

Configure the TCPA-Q Array in multiple ways to meet your outdoor notification needs.

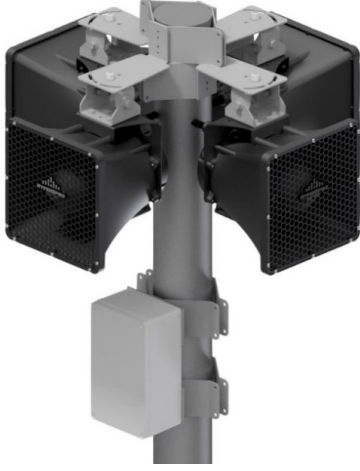

Omni Directional Array

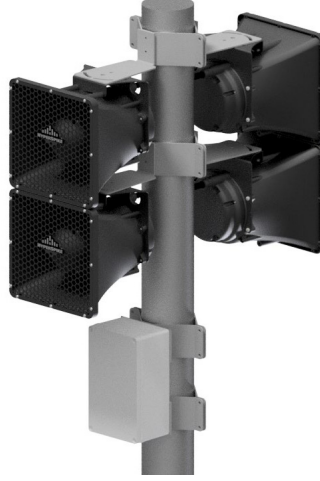

Bi-Directional Array

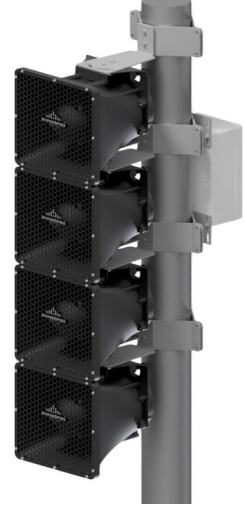

Linear Array

## Acoustic Overlay High School Campus

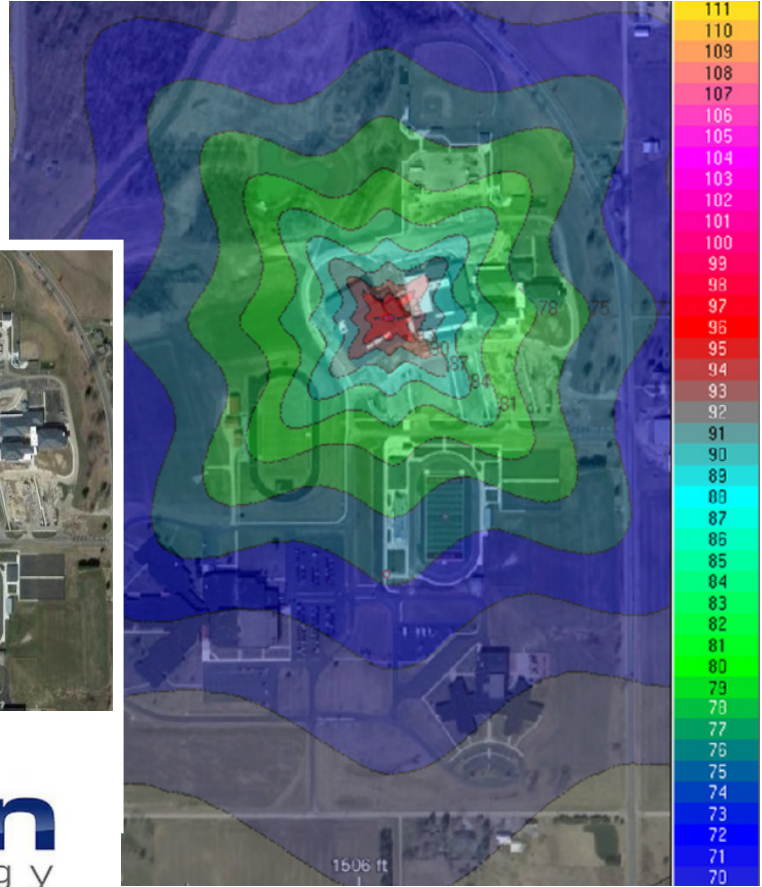

### BALKAN Teknoloji Servisleri Ltd. Şti.

Cumhuriyet Mahallesi, Çimen Sokak, No: 9/A,  
Üsküdar, İstanbul, 34699 TÜRKİYE

Telefon : +90 533 243 55 07

E-mail : [info@balkanteknoloji.com.tr](mailto:info@balkanteknoloji.com.tr)

Web : [www.balkanteknoloji.com.tr](http://www.balkanteknoloji.com.tr)

## ULTRA

90309A-SS-TCPAQ Rev A  
TCPA-Q Array Spec Sheet